

astra pc

astra



www.ilapak.com



PACKAGING MACHINERY

TECHNICAL SPECIFICATIONS

Machine speed	Up to 50 cycles per minute
Film linear speed	Up to 18 m/min with indexer Up to 20 m/min manual feeding Production output depends on film sealability and product characteristics.
Product dimensions	
LENGTH	Up to 650 mm - 25.6" Up to 1200 mm - 47.2"
WIDTH	Up to 300 mm - 12" (jaw width 345 mm - 13.6")
HEIGHT	Up to 240 mm - 9.4"
Film cut-off	Min 100 mm - 4" / ∞ Depending on film and product characteristics.
Wrapping materials	Laminated, co-extruded and all sealable films
Film reel dimensions	
CORE Ø	76,2 mm - 3" standard 152,4 mm - 6" on request
OUTER Ø	350 mm - 13.8"
WIDTH	800 mm - 31.5" standard 900 mm - 35.4" on request
Film reel max weight	Depending on film reel width, up to 75 kg
Electronic platform	Industrial PC
Power requirement	From 220 to 480 V, 50/60 Hz, 5 kVA
Compressed air	6 bar, 200 l/min
Machine weight	1100 kg - 2425 lbs

MAIN STANDARD FEATURES

- Box motion sealing head to optimize sealing cycle.
- 3 AC motors to control indexer, rollers, jaws.
- User friendly 6" colour VGA touch screen operator interface with intuitive icons.
- 64 programs (additional memory on request).
- Automatic product size change.
- Integrated temperature control.
- Electronic diagnostics on-board.
- Variable bag length.
- No product / No bag.
- Misplaced product detection system.
- Ports for peripheral units (printer, labellers, gas control, etc...).
- Programming via AT compatible keyboard.
- Right-hand.
- Robust, hygienic, easy to clean design.

Please discuss your needs with our local representative to configure this machine to your product's specific requirements.

ILAPAK is ISO 9001:2000 certified.

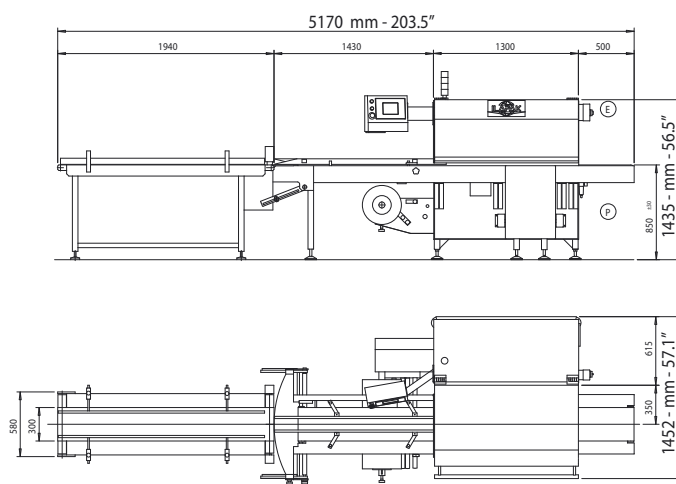

All measurements not specified in inches are given in millimeters.

These specifications are not binding. We reserve the right to change them without prior notice.