

delta

2000 LD



www.ilapak.com



PACKAGING MACHINERY

TECHNICAL SPECIFICATIONS

Machine speed	Up to 60 cycles per minute Production output depends on film sealability and product characteristics.
Product dimensions	
LENGTH	Up to 600 mm - 24"
WIDTH	300 mm - 12" (jaws 345 mm - 13.6")
HEIGHT	Up to 100 mm - 4.0" standard (centre-axle 180) Up to 140 mm - 5.5" on request (centre-axle 215)
Film cut-off	Min 100 mm - 4" / Max 650 mm - 26" Depending on film and product characteristics.
Wrapping materials	Shrink Barrier films, laminated, co-extruded and all sealable films
Film reel dimensions	
CORE Ø	76,2 mm - 3" standard 152,4 mm - 6" on request
OUTER Ø	350 mm - 13.8" standard 400 mm - 15.7" on request (auto-splicer only)
WIDTH	800 mm - 31.5" standard 500 mm - 19.7" standard (wet-wipes only) 650 mm - 25.6" on request 900 mm - 35.4" on request
Film reel max weight	Depending on film reel width, up to 75 kg
Electronic platform	Industrial PC For USA & Canada, in particular, Allen Bradley platform available.
Power requirement	From 220 to 480 V, 50/60 Hz, 5 kVA
Compressed air	6 bar, 200 l/min
Machine weight	1200 kg - 2700 lbs

MAIN STANDARD FEATURES

- Long-dwell sealing head to optimize sealing cycle.
- 3 AC motors to control infeed, rollers, jaws (additional motors with automatic feeders).
- User friendly 6" colour VGA touch screen operator interface with intuitive icons.
- 64 programs (additional memory on request).
- Automatic product size change.
- Integrated temperature control.
- Electronic diagnostics on-board.
- No product / No bag.
- Misplaced product detection system.
- Ports for peripheral units (printer, labelers, gas control, etc.).
- Programming via AT compatible keyboard.
- Right-hand.
- Robust, hygienic, easy to clean design.

Please discuss your needs with our local representative to configure this machine to your product's specific requirements.

ILAPAK is ISO 9001:2000 certified.

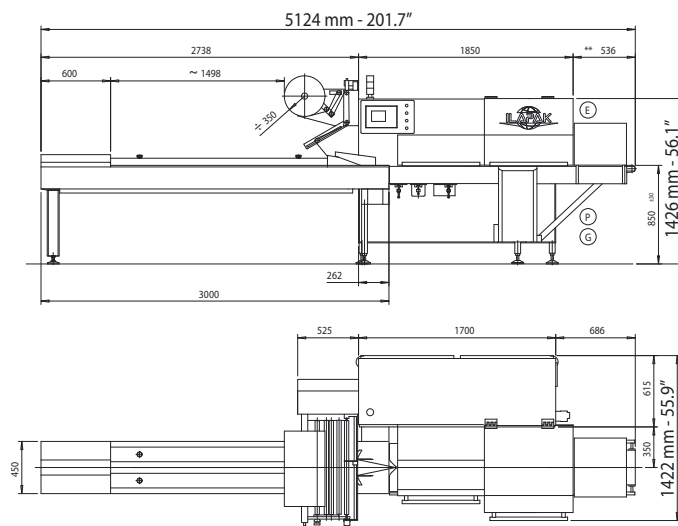

All measurements not specified in inches are given in millimeters.

These specifications are not binding. We reserve the right to change them without prior notice.