

delta

3000 LDR

delta



www.ilapak.com



PACKAGING MACHINERY

TECHNICAL SPECIFICATIONS

Machine speed	Up to 110 cycles per minute Production output depends on film sealability and product characteristics.
Product dimensions	
LENGTH	Up to 650 mm - 25.6" standard Up to 1000 mm - 39.0" on request
WIDTH	320 mm - 12.6" standard (jaws 345 mm - 13.6") 360 mm - 14.2" on request (jaws 440 mm - 17.3")
HEIGHT	Up to 100 mm - 4.0" standard (centre-axle 180) Up to 150 mm - 6.0" on request (centre-axle 225) Up to 60 mm - 2.4" on request (centre-axle 140)
Film cut-off	Min 100 mm - 4" / Max 1200 mm - 47" Depending on film and product characteristics.
Wrapping materials	Shrink Barrier films, laminated, co-extruded and all sealable films
Film reel dimensions	
CORE Ø	76,2 mm - 3" standard 152,4 mm - 6" on request
OUTER Ø	350 mm - 13.8" standard 400 mm - 15.7" on request (auto-splicer only)
WIDTH	650 mm - 25.6" standard 800 mm - 31.5" on request 900 mm - 35.4" on request 1000 mm - 39.4" on request
Film reel max weight	Depending on film reel width, up to 75 kg
Electronic platform	Industrial PC + CAN BUS System For USA & Canada, in particular, Allen Bradley platform available.
Power requirement	From 220 to 480 V, 50/60 Hz, 7 kVA
Compressed air	6 bar, 200 l/min
Machine weight	1500 kg - 3300 lbs

MAIN STANDARD FEATURES

- Long-dwell sealing head to optimize sealing cycle.
- 4 AC motors to control infeed, rollers, jaws, film feed (additional motors with automatic feeders).
- User friendly 10" colour VGA touch screen operator interface with intuitive icons.
- 64 programs (additional memory on request).
- Automatic product size change.
- Integrated temperature control.
- Film tensioning and power unwind system controlled by loadcell.
- Electronic diagnostics on-board.
- No product / No bag.
- Misplaced product detection system.
- Ports for peripheral units (printer, labelers, gas control, etc.).
- Programming via AT compatible keyboard.
- Adjustable folding box.
- Automatic sealing rollers height adjustment.
- Right-hand.
- Robust, hygienic, easy to clean design.

Please discuss your needs with our local representative to configure this machine to your product's specific requirements.

ILAPAK is ISO 9001:2000 certified.

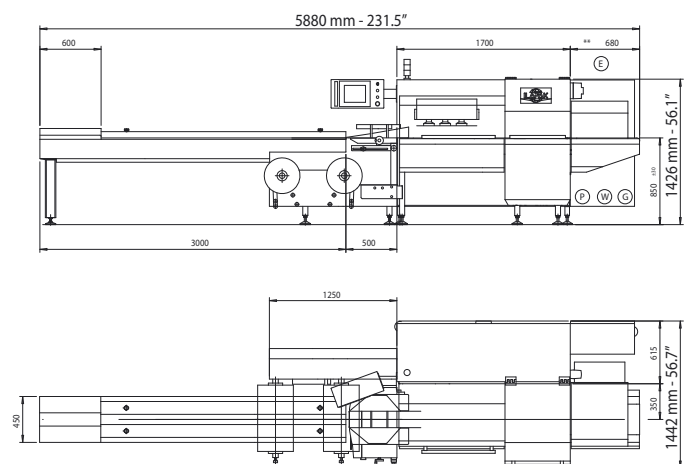

All measurements not specified in inches are given in millimeters.

These specifications are not binding. We reserve the right to change them without prior notice.