

# vegatronic

# 1000

## stainless steel



[www.ilapak.com](http://www.ilapak.com)



PACKAGING MACHINERY

TECHNICAL SPECIFICATIONS	S	P	SP
<b>Machine speed</b>	100 cpm	100 cpm	100 cpm
<b>Bag size</b>			
WIDTH MIN	50 mm - 2.0"	50 mm - 2.0"	50 mm - 2.0"
WIDTH MAX	380 mm - 15.0"	370 mm - 14.6"	380/370 mm - 15.0"/14.6"
LENGTH	380 mm - 15.0"	380 mm - 15.0"	380 mm - 15.0"
<b>Wrapping materials</b>	Heat sealable materials, such as polypropylene, barrier films, laminates, as well as polyethylene films		
<b>Film reel dimensions</b>			
REEL WIDTH MAX	780 mm - 30.7"	780 mm - 30.7"	780 mm - 30.7"
REEL OUTER Ø MAX	500 mm - 19.7"	500 mm - 19.7"	500 mm - 19.7"
REEL CORE Ø MAX	76 mm - 3.0"	76 mm - 3.0"	76 mm - 3.0"
<b>Film reel max weight</b>	100 kg - 220 lbs	100 kg - 220 lbs	100 kg - 220 lbs
<b>Sealing system</b>	----- Motorized horizontal sealing jaws - Pneumatic vertical seal bar -----		
	Standard heat-seal jaws and vertical seal bar	Ilaseal or Ilatherm constant/impulse heating	Both S & P systems
<b>Electronic platform</b>	----- PLC Omron ----- For USA & Canada, in particular, Allen Bradley platform available.		
<b>Program memory</b>	----- 40 programs -----		
<b>HMI</b>	----- 5" monocolour touch screen -----		
<b>Power req.</b> (optionals excluded)	----- AC 400 V+/-5%, 3 phase, neutral, 50 Hz, 4.2 kW, 6.5 A -----		
<b>Compressed air</b>	350-500 NI/min, 7 bar	500-900 NI/min, 7 bar	Same as per S or P
<b>Machine finish</b>	----- Stainless steel version -----		
<b>Machine handing</b>	----- Right hand version, left hand version* -----		
<b>Machine dimensions</b>	----- (width x depth x height) 1286 x 2417 x 1530 mm - 50.6" x 95.2" x 60.2" -----		
<b>Machine weight</b>	----- Approx. 800 kg - 1763 lbs -----		

\*optional

**PACK STYLES**

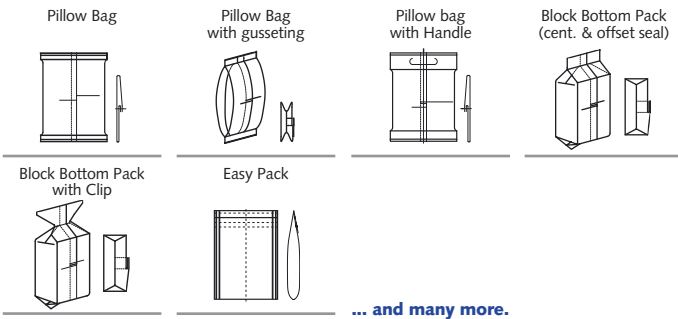

Please discuss your needs with our local representative to configure this machine to your product's specific requirements.

ILAPAK is ISO 9001:2000 certified.

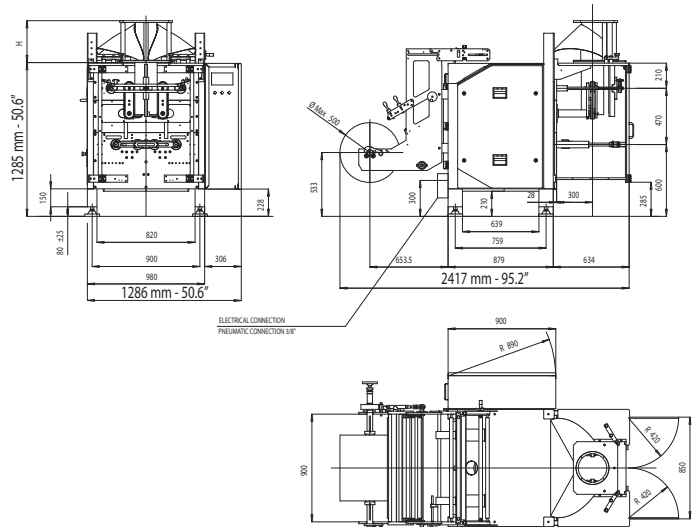

All measurements not specified in inches are given in millimeters.

These specifications are not binding. We reserve the right to change them without prior notice.