

vegatronic 500



www.ilapak.com



PACKAGING MACHINERY

TECHNICAL SPECIFICATIONS	S	P	SP
Machine speed	120 cpm	120 cpm	120 cpm
Bag size			
WIDTH MIN	50mm-2.0"	50mm-2.0"	50mm-2.0"
WIDTH MAX	270/280*mm-10.6/11.0"	260/270*mm-10.2/10.6"	270/280*mm - 260/270*mm
LENGTH	330mm-13.0"	330mm-13.0"	330mm-13.0"
Wrapping materials	Heat sealable materials, such as polypropylene, barrier films, laminates, as well as polyethylene films.		
Film reel dimensions			
REEL WIDTH MAX	580mm-22.8"	580mm-22.8"	580mm-22.8"
REEL OUTER Ø MAX	400mm-15.7"	400mm-15.7"	400mm-15.7"
REEL CORE Ø MAX	76mm-3.0"	76mm-3.0"	76mm-3.0"
Film reel max weight	100Kg-220lbs	100Kg-220lbs	100Kg-220lbs
Sealing system	Brushless motor driven horizontal sealing jaws-Pneumatic vertical seal bar		
	Standard heat-seal jaws and vertical seal bar	laseal sealing system	Both S & P system
Electronic platform	PLC Omron for USA & Canada, in particular Allen Bradley platform available		
Program memory	40 programs		
HMI	5" monocolour touch screen		
Power req. (optional excluded)	AC 400 V+/-5%, 3 phase, neutral, 50Hz,3.3kW, 5 A		
Compressed air	750-1000NI/min, 7 bar-101.5 psi	750-1000NI/min, 7 bar-101.5 psi	Same as per S or P
Machine finish	Electrostatic epoxy powder coating-Stainless steel version *		
Machine handing	Right hand version, left hand version *		
Machine dimensions	(Width x Depth x Height) 1206 x 1945 x 1375 mm - 47.5" x 76.5" x 42.9"		
Machine weight	Approx. 600kg – 1323lbs		

* optional

MAIN FEATURES

- PLC-controlled machine with touch-screen display
- Multi-language interface
- Easily programmable 40 product recipes
- Digital speed display
- Integrated temperature control
- Machine diagnostics
- Access password
- Robust mechanical construction with small footprint
- Reduced product drop height
- Configuration for PE and heat-sealable films
- Servo-driven horizontal jaw carriage
- Quick bag size change-over
- Bag length electronically measured and adjustable
- No-fill-no-bag function
- Complete synchronization of ancillary equipment such as weigher, printer, labeller, dosers, etc.

PACK STYLES

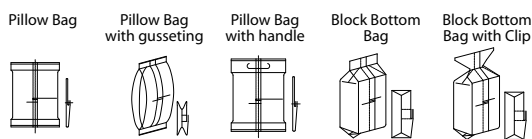

...and many more

Please discuss your needs with our local representative to configure these machines to your product's specific requirements.

ILAPAK is ISO 9001:2000 certified

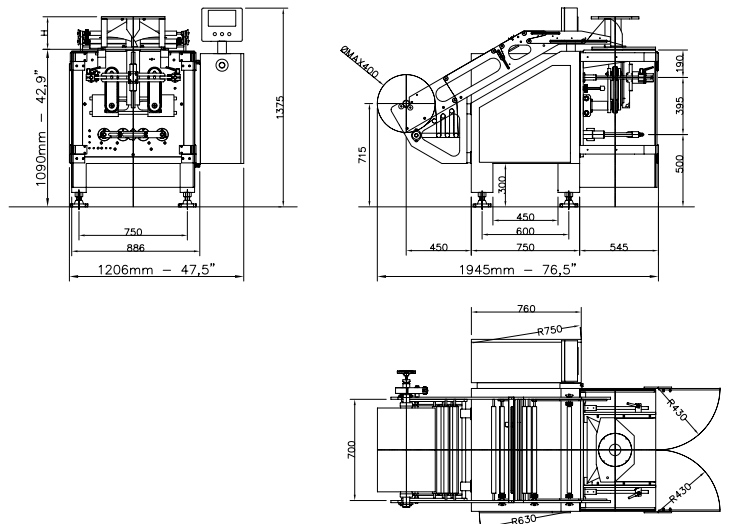

All measurements not specified in inches are given in millimeters.

These specifications are not binding. We reserve the right to change them without prior notice.