

weightronic

10-50



www.ilapak.com



PACKAGING MACHINERY

TECHNICAL SPECIFICATIONS

Buckets	Springless type, double flap. Single flap for fragile products on request
Heads	10
Volume	5 liter
Design	Easy to clean concept Leak-proof execution*
Drive	High speed stepper motors
Product distribution	Vibrated distribution cone with loadcell to control product infeed Rotary distribution cone with loadcell to control product infeed*
Product contact parts	Embossed stainless steel plate
Weighing speed	Up to 70 wpm depending on product characteristics, target weight, tolerance and feeding conditions
Power supply (opt. excluded)	AC 110-230 V+/-5%, 1 phase, neutral, earth, 50 Hz, 2 A, 0.9 Kw
Compressed air (opt. excluded)	7 bar
Electronic platform	Industrial PC
HMI	10" colour touch screen
Programs memory	100 programs
Loadcells	C3 accuracy class, OIML approved R76 class
Machine finish	AISI 304
Protection grade	IP 65. IP 66*
Machine dimensions	(width x depth x height) 1587x1517xh1500-2000 mm
Machine weight	Approx.610 Kg - 1345 lb

* optional

MAIN STANDARD FEATURES

- Full stainless steel execution
- IP65 protection rate (higher on request)
- Plain or embossed* stainless steel plate execution
- Springless hoppers driven by stepper motors
- Fully enclosed radial feeder drives
- Tools-free quick-release contact parts
- Industrial PC with 10" LCD-TFT multicolour touch screen display
- Weighing or counting software mode

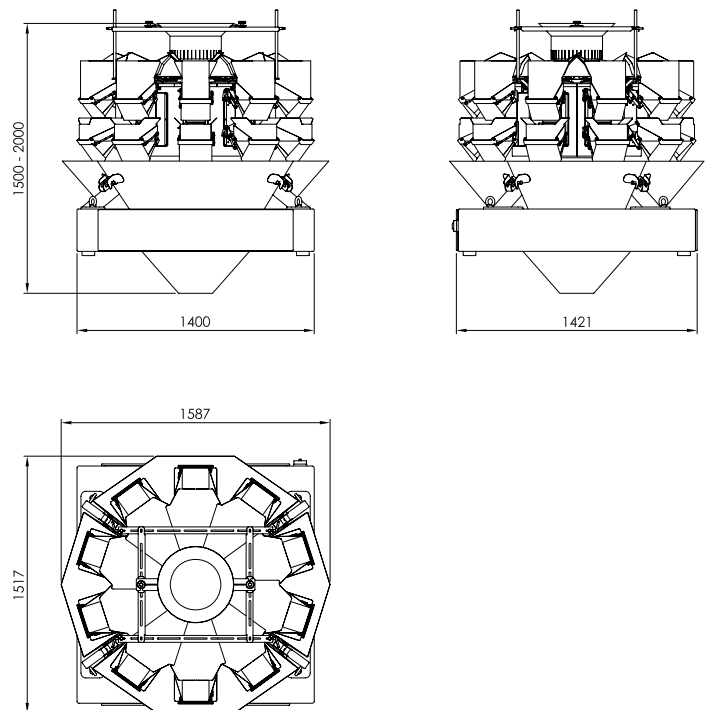

Please discuss your needs with our local representative to configure these machines to your product's specific requirements.

ILAPAK is ISO 9001:2000 certified

All measurements not specified in inches are given in millimeters.

These specifications are not binding. We reserve that right to change them without prior notice.